

# Pressure Switches (Diaphragm Actuator)

SZ□□□D



## Features

- The pressure switches adapt to high pressure and extremely low differential (dead band) at the same time.
- The switches adapt up to the maximum range of 28MPa.
- A SUS316L diaphragm is adopted as a pressure sensing element.
- The diaphragm actuated pressure switches can be used for various pressure medium such as air, water, oil, gases and steam.
- CCC approved

Type of Micro Switches	Models	Range MIN. : Minimum setting point of falling pressure. MAX. : Maximum setting point of rising pressure. MPa (kgf/cm <sup>2</sup> ) MIN. - MAX.	Differential (Dead Band) Add to the Range Value (Representative Value of the middle range.) MPa (kgf/cm <sup>2</sup> )	Rated Pressure Maximum Pressure in Continuous Use MPa (kgf/cm <sup>2</sup> )	Proof Pressure MPa (kgf/cm <sup>2</sup> )
SPDT (C contact only)	SZ1.7D	0.002-0.17 (0.02-1.7)	0.003 (0.03)	2.3 (23)	3.5 (35)
	SZ005D	0.005-0.5 (0.05-5)	0.005 (0.05)	2.3 (23)	3.5 (35)
	SZ025D	0.02-2.5 (0.2-25)	0.025 (0.25)	7 (70)	12 (120)
	SZ035D	0.05-3.5 (0.5-35)	0.05 (0.5)	10 (100)	41 (410)
	SZ070D	0.1-7 (1-70)	0.12 (1.2)	12 (120)	41 (410)
	SZ120D	0.2-12 (2-120)	0.2 (2)	15 (150)	41 (410)
	SZ280D	0.2-28 (2-280)	0.7 (7)	35 (350)	42 (420)

- The differential (dead band) is not adjustable.
- The differential (dead band) indicates value at the middle of the pressure range. The differential (dead band) becomes smaller than the indicated value within the lower range, and larger within the higher range.
- The set point must be within the range.
- Only SPDT (C contact) is available.

SZ1.7D  
SZ005D  
SZ025D

Mass : approx. 1.10kg

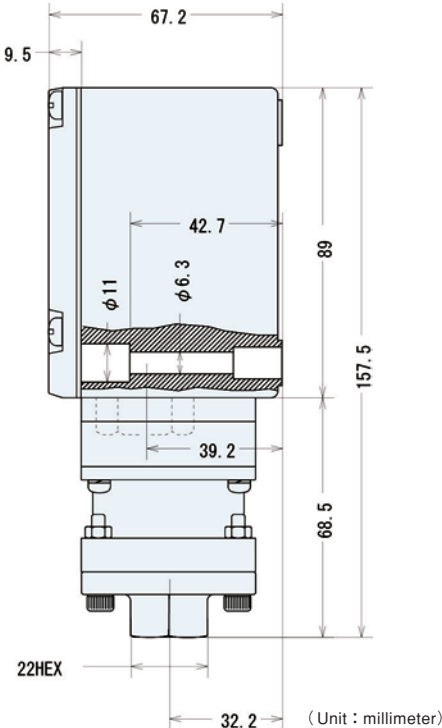
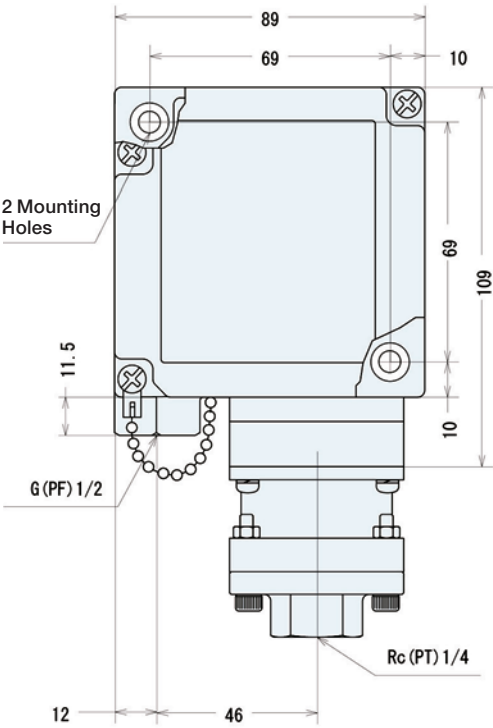

SZ035D  
SZ070D  
SZ120D  
SZ280D

Mass : approx. 0.90kg

