

Explosion-proof Type Compound Vacuum Pressure Switches (Bellows Actuator)

TEX□-Z□□□BR



Features

- The explosion-proof type compound vacuum pressure switches can be used within vacuum to positive pressure range. They can be set within vacuum pressure range only, from vacuum to positive pressure range or within positive pressure range only.
- Setting at the atmospheric pressure (gauge pressure = 0) can also be done.
- The pressure switches have adopted a phosphor bronze bellows actuator as the pressure sensing element.
- The pressure switches can be used for various pressure medium such as air, water, oil, gases and steam.
- The micro switch is selectable from a SPDT standard rating type, a micro-load type (for 24VDC), and a sealed type (environment resistance).
- ExdIICT6 (explosion-proof class) approved.

Models	Range MIN. : Minimum setting point of falling pressure. MAX. : Maximum setting point of rising pressure. MIN. - MAX.	Differential Add to the Range Value kPa (kgf/cm ²) MIN. - MAX.	Rated Pressure Maximum Pressure in Continuous Use	Proof Pressure kPa (kgf/cm ²)
TEX1-Z001BR	80kPaVac-100kPa (600mmHgV-1kgf/cm ²)	10-40 (0.1-0.4)	100kPaVac-100kPa (760mmHgV-1kgf/cm ²)	300 (3)
TEX1-Z005BR	73kPaVac-500kPa (550mmHgV-5kgf/cm ²)	20-100 (0.2-1)	100kPaVac-500kPa (760mmHgV-5kgf/cm ²)	900 (9)
TEX1-Z009BR	67kPaVac-900kPa (500mmHgV-9kgf/cm ²)	40-200 (0.4-2)	100kPaVac-900kPa (760mmHgV-9kgf/cm ²)	2000 (20)

- Beside the adjustable differential (dead band) type, the fixed differential type (symbol "F") is available.
- The minimum (MIN.) differential (dead band) indicates values at the middle of the pressure range. The differential (dead band) becomes smaller than the indicated value within the lower range, and larger range within the higher range.
- The differential (dead band) of the fixed differential type ("F") is less than or equal to the minimum value of the adjustable differential (dead band) type.
- The bellows type pressure switches can be used for various pressure medium such as air, water, oil, gases and steam. However, when you use a bellows type pressure switch for such application as water or oil, you should restrain possible pulsation or surge pressure in your system at minimum. It is recommended to use a damper for an application of which surge pressure is high.
- Normal operating pressure should be below the rated pressure.
- Life duration of bellows is largely influenced by amplitude of setting pressure and fluctuation range of pressure applied to the bellows. It does not always correspond to number of times of a pressure switch actuation. Check high and low setting points, rated pressure and proof pressure value of a pressure switch, so that you select an appropriate model that meets your application.
- The larger number of pressure cycles applied to a bellows is, shorter life duration of it.
Note that metal fatigue of a bellows accumulates according to pressure cycles even if they do not actuate a pressure switch.

TEX1-Z001BR

Mass : approx. 2.3kg

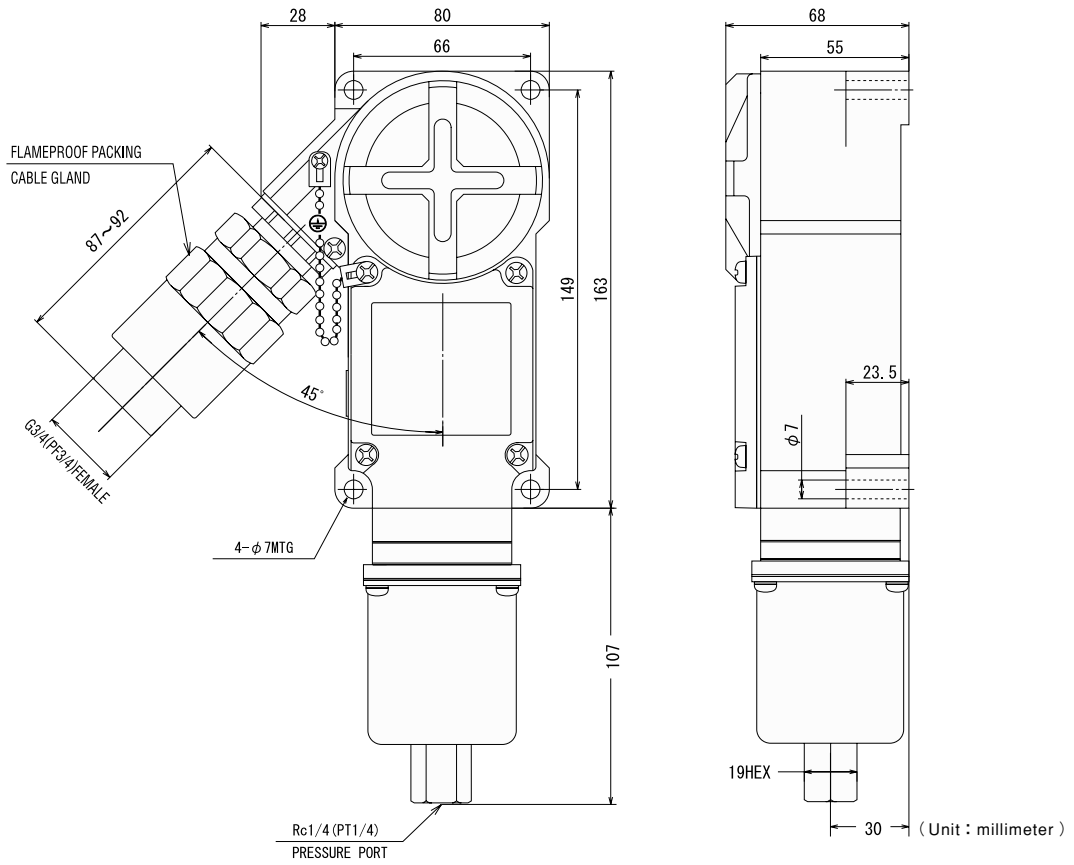

TEX1-Z005BR TEX1-Z009BR

Mass : approx. 2.1kg

